



STRAMIT[®]
RAINWATER
PRODUCTS
WESTERN AUSTRALIA

p r o d u c t t e c h n i c a l m a n u a l



STRAMIT® RAINWATER PRODUCTS WESTERN AUSTRALIA

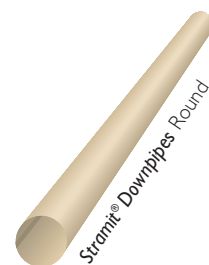
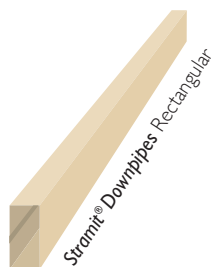
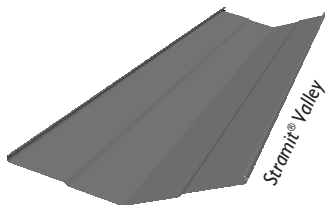
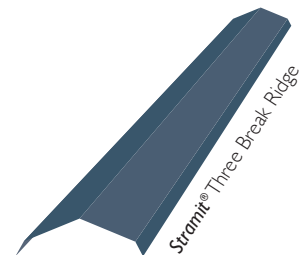
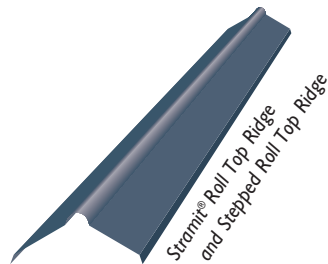
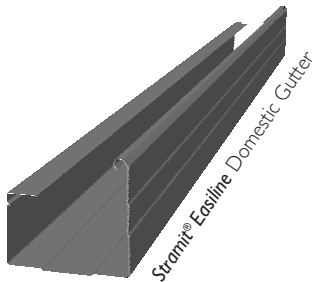
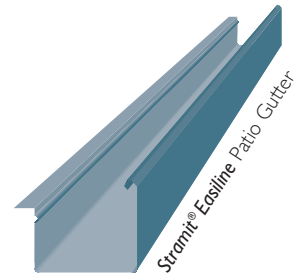
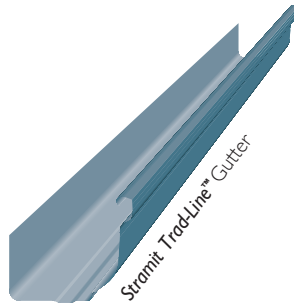
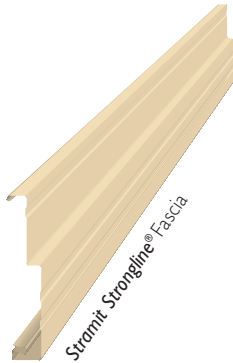

IMPORTANT NOTE

The information contained within this brochure is for general use and information only. Before application in a particular situation, Stramit recommends that you obtain appropriate independent qualified expert advice confirming the suitability of product(s) and information in question for the application proposed. While Stramit accepts its legal obligations, be aware however that to the extent permitted by law, Stramit disclaims all liability (including liability for negligence) for all loss and damage resulting from the use of the information provided in this brochure.

Selection & Specification

General Features

- Extensive range – quality rainwater products.
- Both colour and zinc/aluminium alloy finishes available.
- A comprehensive range of accessories available.
- Extensive design data provided.
- Hi-tensile gutters available.

Applications

Stramit[®] rollformed rainwater products are designed for domestic and light commercial applications, with a comprehensive range of colours to choose from. All products have a wide range of matching accessories.

Stramit Strongline[®] Fascia is an innovative steel stepped fascia developed specifically for the West.

Stramit Trad-Line[™] Gutter has more drainage capacity and a classical style. **Stramit Easiline** Patio Gutter has a neat and economical featured style and is adapted for home improvement use, particularly new projects.

Stramit Easiline Domestic Gutter is another attractive square profiled gutter that is ideal for home improvements. The reverse lip can be tabbed and folded out, providing maximum versatility when replacing existing guttering.

The extensive range of **Stramit Downpipes** provides for the full range of domestic, commercial and most industrial applications. Smaller sizes are available in colours. The full complement of **Stramit Rainwater Products** is completed with valley gutter, ridge capping, edge roll and flashings.

For larger commercial and industrial applications folded **Stramit Custom Flashings** are available to suit any box gutter or eave gutter design.

Availability

All of the **Stramit Rainwater Products** listed in this manual are available in Western Australia. However, items available cut-to-length or from stock vary at each Stramit location. Please check with your nearest Stramit office or the Stramit Western Australia Price & Service Guide for a schedule of availability.

Materials

Stramit Rainwater Products are manufactured from G550 and G300 Zinc Aluminium or Zinc Aluminium Magnesium coated (AZ150/AM125) or galvanized (Z275) steel in accordance with AS1397, and COLORBOND[®] steel with a coating conforming to AS2728. Other coatings, grades and materials may be available, subject to enquiry. The mass and steel grade for the primary **Stramit Rainwater Products** are shown below:

STRAMIT [®] RAINWATER PRODUCTS – MATERIALS & MASS			
	steel grade	mass (kg/m)	
		ZA	CB
Stramit Strongline [®] Fascia	G300	1.49	1.51
Stramit Trad-Line [™] Gutter	G300	0.94	0.96
Stramit Easiline Patio Gutter	G550	1.18	1.20
Stramit Easiline Domestic Gutter	G550	1.18	1.20
Stramit Roll Top Ridge	G300	1.28	1.31
Stramit Stepped Roll Top Ridge	G330	1.28	1.31
Stramit Three Break Ridge	G300	various	
Stramit Valley	G300	1.29	1.31
Stramit Downpipes	G300	various	

Adverse Conditions

Stramit Rainwater Products coated with zinc-aluminium / zinc-aluminium-magnesium alloy and Colorbond[®] steel will give excellent durability in almost all locations more than 200m from a marine environment or in some light industrial applications. For installations closer to the coastline, please contact Stramit for advice.

Applications close to industrial or unusually corrosive environments will need to be individually assessed for durability. Contact your nearest Stramit office for advice.

Stramit Rainwater Products are only intended for use in commercial / industrial / residential rainwater applications. Do not use for any other purpose.

Colours

Most **Stramit**® products are available in the full range of colours. A range of premium products is also available. In addition other colours including some doublesided finishes are stocked at some locations. Please check with your nearest Stramit office or distributor for availability.

Material Compatibility

Drainage from copper or lead products (including roof flashings) should not be allowed to discharge on to zinc/aluminium, zinc/aluminium/magnesium alloy or coloured components. Similarly, lead or copper components should not be installed in contact with zinc/aluminium or zinc/aluminium/magnesium alloy. Each of these combinations will lead to premature corrosion.

Drainage from copper, coloured, zinc/aluminium, zinc/aluminium/magnesium alloy, translucent (or other inert material) should not be allowed to discharge onto, or into, galvanised products.

Fascia/Gutter Compatibility

In order to achieve a high quality finish to your project it is recommended that only **Stramit**® Gutters, **Stramit Strongline**® Fascia and authentic **Stramit**® accessories are used.

Testing

Stramit has in-house, purpose built testing equipment used to design, develop and improve products for the Australian market. In addition many Stramit products are tested or witnessed by independent organisations. These include:

- University of Technology, Sydney
- Cyclone Structural Testing Station (James Cook University)
- The University of Sydney
- CSIRO

The ongoing research and development activity ensure that Stramit remains at the forefront of innovation, design and consumer information.

Architectural Specification

A similar specification for each product can be found on the Stramit web site and can easily be downloaded onto your documentation.

The [product type – e.g. gutter] shall be Stramit [product name – e.g. Trad-Line] or agreed exact equivalent in size and performance. Material shall be protected steel sheet to Australian Standard AS1397 with a minimum yield stress of 550MPa* and an AM100/AZ150* coating with an oven-baked paint film of selected colour, or a plain AM125/AZ150* coating. All accessories are to be fully compatible as recommended by the manufacturer.

The product and its accessories shall be installed strictly in accordance with the manufacturer's recommendations. Flashings and all adjacent products shall be supplied in compatible materials as specified. All work shall be fixed in a workman like manner, leaving the job clean and weather tight. All debris (screws, rivets, cuttings and filings, etc) shall be cleaned off daily. Repair all minor blemishes with an approved touch up paint.

NOTE – *some products supplied in 300MPa steel with galvanised Z275 coating.

Standards Conformance

All **Stramit**® **Rainwater Products** are conformant with, or equivalent to AS2179. Data given in this manual therefore assumes drainage from the bottom of each gutter.

Gutter Overflow

Gutter overflow needs to be considered when designing and installing gutter systems. The overflow devices should have adequate capacity and the roof drainage system must be in accordance with AS 3500.3. Detailed information is provided in this document on pages 6 and 7.

Design

GENERAL

Performance

Stramit® Rainwater Products have been designed and/or tested to all appropriate loadings and design action effects. These include wind, atmospheric corrosion, rainwater flow, rainwater mass, foot traffic loads, dead loads and ladder loads. The performance information for each product indicates those action effects accounted for in each case.

Rainfall Intensity

Values of rainfall intensity in the table are for 20 and 100 year ARI, 5 minute durations and have been derived from the National Construction Code 2016. It should however be emphasised that the extent and longevity of records in Australia are limited and any such data therefore carries with it a degree of uncertainty. The 20 year ARI values should only be used for external eave gutters. For internal/box gutters and overflow design use the 100 year ARI values included in the table below.

RAINFALL INTENSITIES (mm/hr)		
Western Australia		
	20 year	100 year
Albany	127	178
Broome	232	287
Bunbury	148	199
Carnarvon	136	202
Collie	126	166
Dampier	137	188
Derby	211	256
Donnybrook	134	178
Esperance	115	162
Geraldton	138	193
Kalgoorlie	137	204
Katanning	125	181
Meekatharra	143	221
Northam	109	158
Perth	130	172
Joondalup	133	180
Midland	122	163
Port Hedland	168	230
Tom Price	138	182

Specific data for any location can be obtained from the Bureau of Meteorology website, based on the latitude and longitude.

Hail

Experience has shown that **Stramit®** steel gutters are able to resist impact from significantly sized hail without damage. However, in hail prone areas consideration should be given to ensuring that gutter fronts are well below roof level. This should avoid the damming effect of hail which, if it builds up onto the roof, can lead to overloading and failure of the gutter.

Leaves

Leaves in gutters can be a problem. They come in many shapes and sizes and roof debris may also include branches, twigs and both organic and inorganic particles. Many systems have been and are used to try to solve this problem. The optimum solution will vary with each situation and may be influenced by a number of factors that include the nature and proximity of vegetation, the level of maintenance and the primary motivation (eg water collection, maintenance reduction, gutter system durability, bushfire hazard reduction etc).

One method is to use adequately sized gutters set well below the roof edge with a good fall and large downpipes with well angled offsets to avoid corner blockages, clear frequently and remove overhanging vegetation.

An often-used method is an additional mesh guard or perforated gutter covering. Those of a very fine mesh will keep most debris from the gutters but can be prone to dirt and algal build up leading to mesh blockage. This does keep leaves from the gutter and downpipe, but ultimately it may not allow water to pass into the gutter. Any water trapped within the gutter may not dry out which could compromise durability.

Larger mesh guards stop large leaves and branches from entering the gutter but it may be possible for twigs and branches to catch in the mesh ultimately creating a dam causing water to flow back into the building eaves.

It is also important, if a cover or leaf guard is used, that it is material-compatible with the gutter and that both the gutter and the guard are cleared regularly.

DESIGN FACTORS

In the design and detailing of a roof drainage system, consideration must be given to a range of factors such as rainfall intensity, roof catchment area, gutter size/capacity, gutter fall, gutter outlets (sumps, rainwater heads, nozzles), downpipes (size, quantity and placement), overflow consideration, material selection, jointing, etc.

Building Code Compliance

Under the Environmental Planning and Assessment Act 1979 and its regulations, all building work must be carried out in accordance with the Building Code of Australia (BCA), now part of the National Construction Code (NCC). In addition to referring to Australian Standards AS/NZS 3500.3, and AS/NZS 3500.5, the BCA also contains requirements for the disposal of surface water in Volume One, Performance Requirements FPI.2 and FP 1.3, and in Volume Two, Part 3.5.2, namely, Performance Requirement P2.2.1 and Clauses 3.5.2.1. to 3.5.2.5.

The most common means of satisfying these requirements for roof drainage (i.e. guttering) installations is by complying with the National Plumbing and Drainage Code AS/NZS 3500.3.

Furthermore, in each state and territory it is necessary to satisfy the relevant regulation.

High Front Gutters

High front gutters are commonly used in residential roof drainage systems to conceal the lower edge of roof cladding or tiles. These gutters form part of the roof drainage system, which is required to comply with the National Construction Code. Details of the design process for roof drainage systems, which includes selecting overflow measures, are given in the National Plumbing and Drainage code AS/NZS 3500.3. Information on overflow measures is also given in the National Construction Code.

Overflow Provision

The Building Code of Australia requires that where high-fronted gutters are installed provision must be made to avoid any overflow back into the roof or building structure by incorporating overflow measures or the like. This requirement does not apply where the gutter is connected to a verandah or where the eave is more than 450mm wide, with either no lining or raked with a slope towards the gutter. Overflow design must be based on the 100 year ARI 5 minute duration rainfall intensity.

Methods of providing for overflow in the design and installation of roof drainage systems with high front gutters may include:

- Slotted gutter front to allow for water overflow through the slots visible on the front face of the gutter.
- Gap between the fascia and the gutter back, either by inserting a packer between the back of the gutter and the fascia or by employing proprietary systems and trade solutions.
- Specific overflow measures, such as:
 - Inverted downpipe drop/pop nozzle at high points in the gutter but set at a level below the fascia top.
 - Stop ends cut down to a lower level to act as a weir. Stop end weirs could be hidden at the high point of the gutter and designed as part of an expansion joint.
 - Rainwater heads with overflow weir
 - Holes, slot, or weir at downpipes

Examples of continuous and non-continuous overflow measures are illustrated on page 7. Slotted gutters may also provide an adequate overflow measure in some applications. In high rainfall intensity regions a combination of overflow methods may be required.

Alternative Overflow Measures

Overflow may also be addressed through alternative building design methods, such as:

- Unlined eaves, where appropriate to the house design, to eliminate the issue.
- Gutter installed so that the gutter front is 10mm below the top of the fascia.
- Back flashing, where gutter support brackets allow for installation of back flashing (e.g., external brackets).

The detailing and sizing of the selected overflow method/s is normally completed by the designer/installer, but must be adequate for the situation and must meet the relevant performance requirements of the NCC and Australian Standards.

Maintenance Considerations

In the longer term, the ability of a roof drainage system to handle overflow will also depend on the regular cleaning of the system. For example, the removal of plant or animal matter (leaves, fungal growth, droppings, nests, etc.) and debris from gutters, leaf-guard systems and the gutter overflow devices to ensure free drainage of water.

Adequate maintenance is a requirement of rainwater goods warranties.

Installer Responsibility

While there may be variations between states, contractors who install guttering systems are generally required to hold an appropriate licence. The work is required to comply with the appropriate codes and standards. Statutory warranties normally apply and consumers have a right to lodge a complaint with the appropriate authority.

During the installation of the roof drainage system, particular attention should be given to the following:

- The use of compatible materials for drainage system components, leaf-guard system components and fasteners/sealants to connect and seal the components.
- The position of the gutter in relation to the fascia.
- Installation of the specified gutter and downpipes, and ensuring that downpipes are installed in the correct locations and numbers.
- Gutter fall, ensuring sufficient fall in the direction of the downpipes.
- Overflow must be allowed for and specific components installed where required.
- All debris and loose waste materials (swarf, fasteners, etc.) must be cleaned off at the end of each day and at the completion of the installation, to prevent blockages of the drainage system or deterioration of the individual components. Any protective films should also be removed as part of the installation process.

Continuous overflow measures

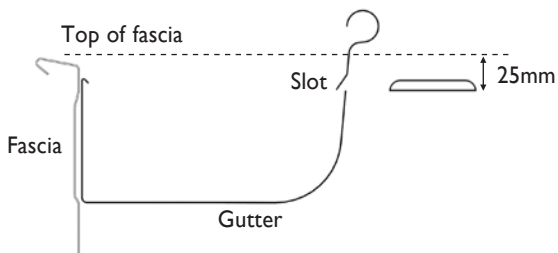

Slotted gutter with slot area 1200mm²/m
– overflow capacity 0.5L/s/m

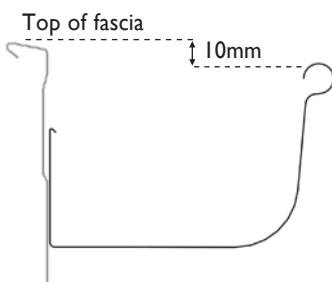

Front of gutter 10mm below top of fascia
– overflow capacity 1.5 L/s/m

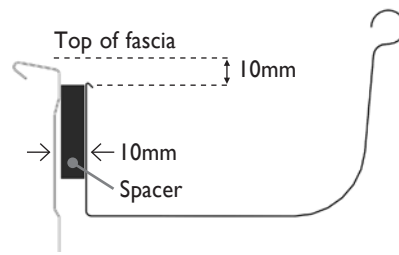

10mm gap between gutter and fascia
– overflow capacity 1.5 L/s/m

Specific overflow measures

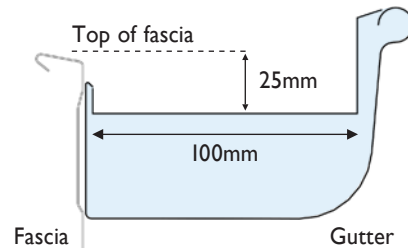

Stop ends finished below top of fascia and rear of gutter to form a weir – overflow capacity 0.5L/s

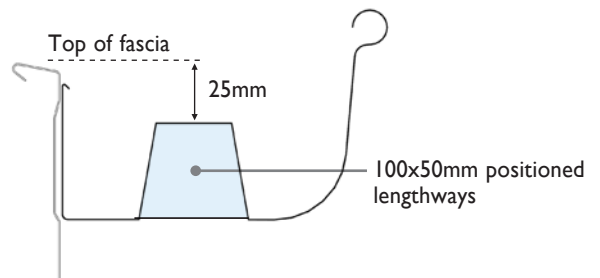

Inverted nozzle at high ends of gutter finished below back of gutter – overflow capacity 1.2L/s

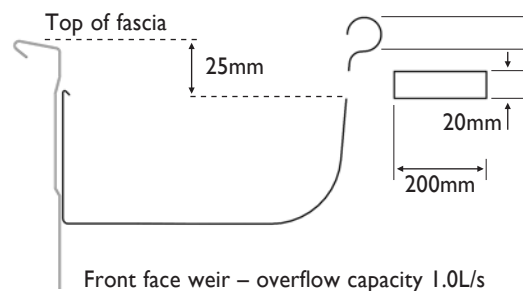

Front face weir – overflow capacity 1.0L/s

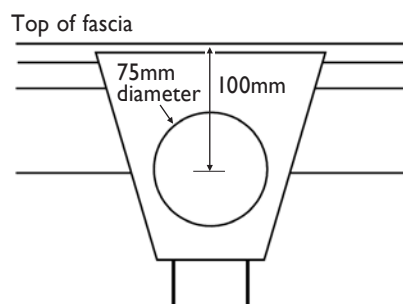

Rainhead – overflow capacity 3.5L/s

STRAMIT® GUTTERS

STRAMIT® GUTTERS – CROSS SECTIONAL AREA (mm²)

Stramit Trad-Line™ Gutter	5200
Stramit® Easiline Patio Gutter	6800
Stramit® Easiline Domestic Gutter	6800

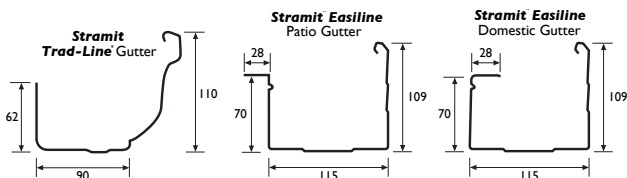

Spans

Stramit® Gutters require the correct proprietary **Stramit®** brackets for support at spacing no greater than those shown in the following table.

STRAMIT® GUTTERS – MAXIMUM SUPPORT SPACINGS (mm)

Stramit Trad-Line™ Gutter	600
Stramit® Easiline Patio Gutter	1000
Stramit® Easiline Domestic Gutter	1200

Thermal Expansion

Straight gutter runs in excess of 20m require the provision of an expansion joint. Where required, details of expansion joints are provided in Standards Australia Handbook HB39.

Gutter Capacity

In theory any size of gutter can be used to drain any roof catchment. What controls design is the number of downpipes needed to perform within the capacity of each gutter. In practice the larger the gutter the less the number of downpipes required, as indicated in the table [opposite].

Normally catchment calculations must take into account the increased area due to roof slope. The required downpipe table incorporated into this manual takes account of roof slopes up to 23°. Therefore the roof area for use with this table requires only the simple calculation of plan area.

The data given in the tables is based on gutters being installed without fall. For applications where **Stramit®** Gutters are installed with a minimum fall of 1 in 500, less downpipes could be needed. Contact Stramit for revised data if the application has fall.

The data tabulated is also based on downpipes draining from the bottom of the gutter. This method of drainage is

the accepted way in AS3500.3 whereas drainage from the rear of the gutter is not. No data is currently available for drainage from the rear of the gutter. It would be expected however that additional downpipes would be needed to achieve a comparable drainage capacity.

STRAMIT STRONGLINE® FASCIA

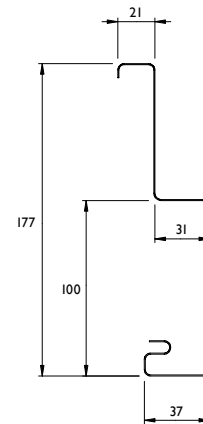

Spans

The continuous spanning capability of **Stramit Strongline®** Fascia shown has been determined by testing (in accordance with AS4040.1) for a combination of roof tile and foot traffic loads. The maximum spacing of **Stramit Strongline®** Fascia rafter brackets is 1500mm.

Pressures

The wind resistance of **Stramit Strongline®** Fascia has then been determined at these spans by testing in accordance with AS4040.2 – and for each of the spans is suitable for use in areas of up to: 1.0 kPa SERVICEABILITY LIMIT-STATE, 2.4 kPa STRENGTH LIMIT-STATE. These pressures are equivalent to: N3 (Region A – rural, Region B – exposed suburban).

Gutter Style			Max area per downpipe (m ²)	STRAMIT® GUTTERS & DOWNPIPES - NUMBER OF DOWNPIPES REQUIRED FOR TYPICAL ROOF INSTALLATION (GUTTERS WITH ZERO FALL)											
Stramit® Trad-line™	Stramit® Easiline Patio	Stramit® Easiline Domestic		roof plan area(m ²) – for roofs up to 23°											
Location Rainfall Intensity (mm/hr)				100	120	140	160	180	200	220	240	260	280	300	
110	110	110	43	3	4	4	5	6	6	7	7	8	8	9	
	120	120	39	4	4	5	5	6	7	7	8	8	9	10	
	130	130	36	4	4	5	6	6	7	8	8	9	10	10	
	140	140	34	4	5	6	6	7	8	8	9	10	11	11	
	150	150	32	4	5	6	7	7	8	9	10	10	11	12	
			31	4	5	6	7	7	8	9	10	11	11	12	
			31	4	5	6	7	8	8	9	10	11	12	12	
		160	160	30	5	5	6	7	8	9	9	10	11	12	13
			29	5	5	6	7	8	9	10	10	11	12	13	
	120		28	5	6	7	7	8	9	10	11	12	13	13	
	170	170	28	5	6	7	7	8	9	10	11	12	13	14	
		27	5	6	7	8	8	9	10	11	12	13	14		
	180	180	26	5	6	7	8	9	10	11	12	12	13	14	
130		26	5	6	7	8	9	10	11	12	13	14	14		
	190	190	24	5	6	7	8	9	10	11	12	13	14	15	
140	200	200	23	6	7	8	9	10	11	12	13	14	15	16	
150	210	210	23	6	7	8	9	10	11	12	13	14	16	17	
		22	6	7	8	9	10	12	13	14	15	16	17		
	220	220	22	6	7	8	9	11	12	13	14	15	16	17	
160		21	6	7	9	10	11	12	13	14	15	17	18		
		21	6	7	9	10	11	12	13	14	16	17	18		
	230	230	21	6	8	9	10	11	12	13	15	16	17	18	
		20	7	8	9	10	11	13	14	15	16	17	19		
170		20	7	8	9	10	11	13	14	15	16	18	19		
	240	240	20	7	8	9	10	12	13	14	15	16	18	19	
		19	7	8	9	11	12	13	14	16	17	18	20		
	250	250	19	7	8	9	11	12	13	15	16	17	18	20	
180		19	7	8	10	11	12	13	15	16	17	19	20		
	260	260	18	7	8	10	11	12	14	15	16	18	19	20	
190		18	7	9	10	11	13	14	15	17	18	20	21		
		18	7	9	10	12	13	14	16	17	18	20	21		
200		17	8	9	11	12	13	15	16	18	19	21	22		
210		16	8	10	11	13	14	16	17	19	20	22	23		
220		15	8	10	12	13	15	16	18	19	21	23	24		
230		15	9	10	12	14	15	17	19	20	22	24	25		
240		14	9	11	13	14	16	18	19	21	23	25	26		
250		14	9	11	13	15	17	18	20	22	24	26	27		
260		13	10	12	14	15	17	19	21	23	25	27	28		

Intensities for Perth

Note: Gutter gradient < 1:500

The selection of the number of downpipes is carried out in accordance with AS/NZS 3500.3 (Stormwater drainage).

However, the larger the gutter the larger the downpipe required. The minimum size of downpipe associated with each **Stramit®** Gutter is given in the **Stramit® Downpipes** section that follows.

Overflow Measures

Overflow measures are not required for eaves gutters fitted to a verandah, or where the eave is greater than 450mm wide, with either no lining, or with lining sloping away from the building. Slotted **Stramit**® gutters give some overflow provision. The table below gives the maximum sloped roof run length which can be used for the overflow through the slots, on the Stramit Trad-Line™ gutter.

Roof Run Length

When finding the maximum sloped roof run length, it is important to consider the additional length of roof which contributes to the flow in any one position, if there is a roof penetration or spreader. In these positions, the effective roof run length would be longer than the distance from the ridge to the eaves. A simplified method of finding this length is shown in the illustration. In this case, the maximum roof run length is 14m for a 10m length of roof due to the penetration 4m down from the ridge.

If the catchment area is known, the roof run length can be found by dividing the area by the length of gutter it feeds into.

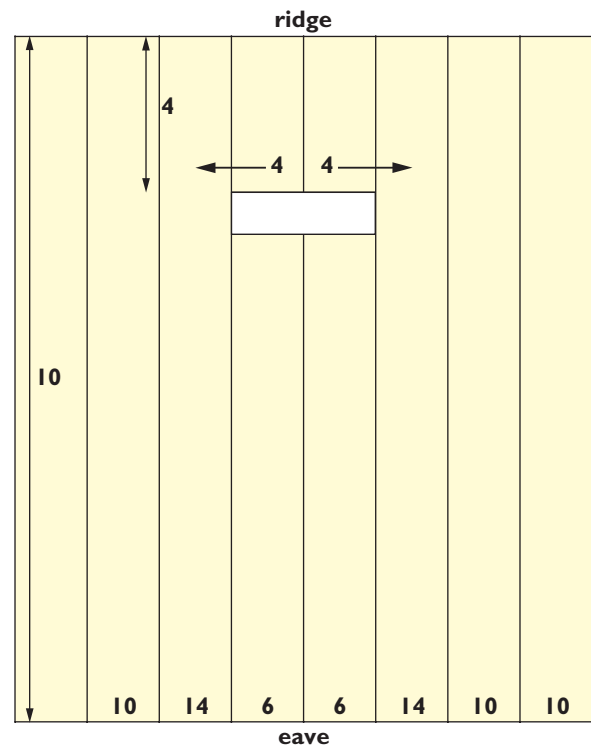

OVERFLOW MEASURES - WESTERN AUSTRALIA

Location	Rainfall Intensity (mm/hr)	Maximum roof length feeding into gutter (m)														
		4.0	4.5	5.0	5.5	6.0	6.5	7.0	7.5	8.0	8.5	9.0	9.5	10.0	10.5	11.0
WA																
Northam	158	0.18	0.20	0.22	0.24	0.26	0.29	0.31	0.33	0.35	0.37	0.40	0.42	0.44	0.46	0.48
Esperance	162	0.18	0.20	0.23	0.25	0.27	0.29	0.32	0.34	0.36	0.38	0.41	0.43	0.45	0.47	0.50
Midland	163	0.18	0.20	0.23	0.25	0.27	0.29	0.32	0.34	0.36	0.38	0.41	0.43	0.45	0.48	0.50
Collie	166	0.18	0.21	0.23	0.25	0.28	0.30	0.32	0.35	0.37	0.39	0.41	0.44	0.46	0.48	0.51
Perth	172	0.19	0.22	0.24	0.26	0.29	0.31	0.33	0.36	0.38	0.41	0.43	0.45	0.48	0.50	0.53
Donnybrook	178	0.20	0.22	0.25	0.27	0.30	0.32	0.35	0.37	0.39	0.42	0.44	0.47	0.49	0.52	0.54
Albany	178	0.20	0.22	0.25	0.27	0.30	0.32	0.35	0.37	0.40	0.42	0.45	0.47	0.49	0.52	0.54
Joondalup	180	0.20	0.23	0.25	0.28	0.30	0.33	0.35	0.38	0.40	0.43	0.45	0.48	0.50	0.53	0.55
Katanning	181	0.20	0.23	0.25	0.28	0.30	0.33	0.35	0.38	0.40	0.43	0.45	0.48	0.50	0.53	0.55
Tom Price	182	0.20	0.23	0.25	0.28	0.30	0.33	0.35	0.38	0.40	0.43	0.46	0.48	0.51	0.53	0.56
Dampier	188	0.21	0.24	0.26	0.29	0.31	0.34	0.37	0.39	0.42	0.44	0.47	0.50	0.52	0.55	0.58
Geraldton	193	0.21	0.24	0.27	0.29	0.32	0.35	0.38	0.40	0.43	0.46	0.48	0.51	0.54	0.56	0.59
Bunbury	199	0.22	0.25	0.28	0.30	0.33	0.36	0.39	0.41	0.44	0.47	0.50	0.53	0.55	0.58	0.61
Carnarvon	202	0.22	0.25	0.28	0.31	0.34	0.36	0.39	0.42	0.45	0.48	0.51	0.53	0.56	0.59	0.62
Kalgoorlie	204	0.23	0.26	0.28	0.31	0.34	0.37	0.40	0.43	0.45	0.48	0.51	0.54	0.57	0.60	0.62
Meekatharra	221	0.25	0.28	0.31	0.34	0.37	0.40	0.43	0.46	0.49	0.52	0.55	0.58	0.61	0.64	0.68
Port Hedland	230	0.26	0.29	0.32	0.35	0.38	0.42	0.45	0.48	0.51	0.54	0.58	0.61	0.64	0.67	0.70
Derby	256	0.28	0.32	0.36	0.39	0.43	0.46	0.50	0.53	0.57	0.60	0.64	0.68	0.71	0.75	0.78
Broome	287	0.32	0.36	0.40	0.44	0.48	0.52	0.56	0.60	0.64	0.68	0.72	0.76	0.80	0.84	0.88

Note: Values in the table are in L/s/m. A measure with a larger overflow volume can be substituted for one which has a smaller volume.

Slot area 1200mm²/m

Slot overflow insufficient, please contact your local Stramit office for advice.

The above data is valid for **Stramit Trad-line™ gutter**. For other gutters, and for information on availability of different overflow options, please contact your local Stramit office for advice.

STRAMIT® DOWNPIPES

Stramit offer a wide range of round and rectangular downpipes, each of which is tapered to permit easy assembly.

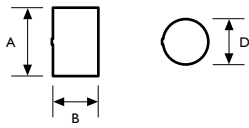

The dimensions and cross-sectional area of all **Stramit® Downpipes** available in Western Australia are shown in the table below.

STRAMIT® DOWNPIPES – SIZES & AREAS				
rectangular			round	
width - A (mm)	depth - B (mm)	area (mm ²)	diameter - D (mm)	area (mm ²)
75	50	3750	75	4420
95	45	4270		
100	50	5000		
100	75	7500		
100	100	10000		

Sizing of minimum downpipe size relates only to the cross-sectional area of the chosen gutter. The table below gives the minimum downpipe size for each **Stramit®** Gutter in accordance with AS3500.3.

STRAMIT® DOWNPIPES – MINIMUM SIZES (mm)	
Gutter	rectangular*
Stramit Trad-Line™ Gutter	100 x 75
Stramit® Easiline Patio Gutter	100 x 75
Stramit® Easiline Domestic Gutter	100 x 50

* Smaller downpipes may be used provided the gutter capacity is reduced in drainage calculations. For round downpipes the maximum gutter area for design must not exceed the downpipe area. For rectangular downpipes the maximum gutter area for design must not exceed the downpipe area multiplied by 1.28.

If using 95 x 45 or Ø75 downpipes with other **Stramit®** Gutters, contact Stramit for further information on the number of downpipes.

OTHER STRAMIT® RAINWATER & FLASHING PRODUCTS

Stramit® Custom Flashings

Stramit® Custom Flashings are available in an almost infinite variety of shapes, sizes and finishes. Preferred girth widths are 150, 240, 300 and 400mm and lengths of up to 8m are possible. The details of all **Stramit® Custom Flashings** must be provided in hard copy (e.g. fax). Contact the nearest Stramit branch for more details or refer to the **Stramit® Price & Service Guide**.

All of the following products require nominally continuous support.

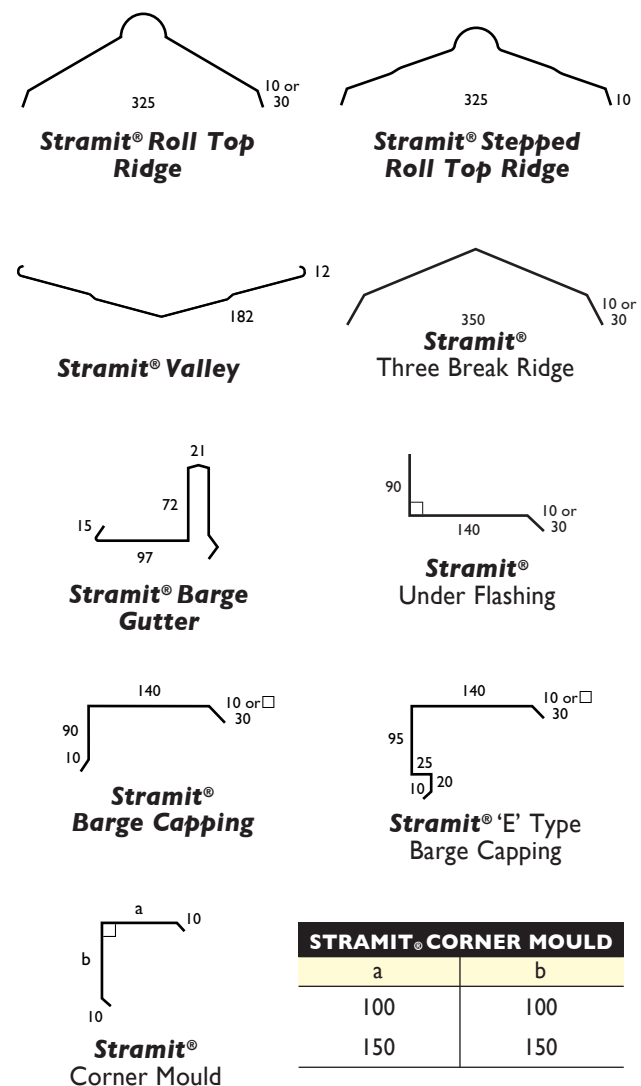

STRAMIT® CORNER MOULD	
a	b
100	100
150	150

Procurement

Accessories

Use only the correct, authentic **Stramit**® Accessories with **Stramit**® Rainwater Products.

The following accessories are available for each product:

Stramit Strongline® Fascia

- Rafter Bracket
- Side Fixing Fascia Brackets
- End Fixing Clips
- Splice Plate
- Bridging Plate
- LH/RH Stop End Plates
- 45°/90°/135° Corners

Stramit® Gutters

- Concealed/General Purpose Bracket
- Internal Brackets (suits **Stramit Trad-Line**™ Gutters for use with **Stramit Strongline**® Fascia)
- T Pattern Internal Bracket (suits **Stramit Trad-Line**™ Gutters)
- **Stramit**® **Easiline** Domestic Gutter

- Stop End Plate (suits **Stramit**® **Easiline** Patio Gutters)
- Universal Gutter Clips
- M Pattern internal bracket (suits **Stramit Trad-Line**™ Gutters)
- Clip D (suits **Stramit**® **Easiline** Patio & **Stramit**® **Easiline** Domestic Gutters)

Stramit® Downpipes

- Straps/Clips
- Pops

Note that in most cases the components shown are different for each particular gutter style or downpipe size.

Associated products

- Roofing – wide range of profiles & accessories available.
- Roof & ceiling battens – range of top hats available.
- Silicone – for all sealing requirements.
- Flashings & cappings – range of standard and custom flashings available.

Prices

Prices of products can be obtained from your nearest Stramit location or distributor of **Stramit**® products. As Stramit does not provide an installation service, ask your tradesperson for a supply and fix price. Contact your nearest Stramit location for the names of tradespeople in your area.

Handling/Storage

Stramit® Rainwater Products should be handled with care at all times to preserve the product capabilities and quality of the finish. Packs should always be kept dry and stored above ground level while on site. If the products become wet, they should be separated, wiped and placed in the open to promote drying.

Ordering

Stramit® Rainwater Products can be ordered directly through distributors, or supplied and fixed from an installer.

Lengths

Most rainwater products are available as stock lengths. **Stramit Strongline**® Fascia, **Stramit**® Gutters and valleys are available cut-to-length from Perth.

Delivery/Unloading

Delivery can normally be made within 48 hours, subject to the delivery location and material availability, or can be at a pre-arranged date and time. Please ensure that suitable arrangements have been made for truck unloading, as this is the responsibility of the receiver. When lifting fascia gutter and flashings, care should be taken to ensure that the load is spread to prevent damage. The protective strippable coating on coloured product should not be exposed to sunlight for more than about one week or this may become difficult to remove.

Installation

Fasteners

All fastening screws must conform to AS3566 – Class 3.
For connecting brackets use:



For fixing **Stramit® Fascia** rafter brackets to steel trusses (up to 2.5mm) – No. 10 x 16mm hex-head self drilling & threading screws.



– to timber trusses – No. 10 x 25mm hex-head type 17 self-drilling screws.



For fixing Gutter Brackets to fascia – No. 10 x 25mm wafer head self-drilling type 17 screws for timber fascia.



- No. 10 x 16 wafer head self-drilling screws for metal fascia.



For lap joints and accessories – 3.2mm diameter aluminium pop rivets.

Cutting

Stramit® Rainwater Products can be easily cut, where required, using a fine-toothed hacksaw and tin snips. Please dispose of any off-cuts carefully.

Sealing

Use only neutral-cure silicone for sealing joints when using **Stramit® Rainwater Products**. Take care to avoid pockets in joints which may hold moisture and potentially reduce durability.

Good Practice

Stramit recommends that good trade practice be followed when using the products such as that found in *Standard Australia Handbook – HB39*. “Installation code for metal roofing and wall cladding”.

Painting

Stramit® Rainwater Products are available in colours. However should painting of zinc/aluminium or zinc/aluminium/magnesium alloy products be required, use the following procedure.

A ‘weathering’ period of two weeks following installation will make painting easier. Clean the gutter/fascia immediately prior to painting. Dirt can be washed off using water with mild detergent. Any grease marks should be wiped away with paint thinners. In benign locations good quality acrylic paint will give satisfactory performance. First use a low-gloss water-borne acrylic primer. Finish with water-borne acrylic gloss (or your choice of gloss level).

WARNING – Never use paint thinners or other solvents on coloured surfaces.

Strippable Coating

Some **Stramit® Rainwater Products** are supplied with a protective strippable coating. This should be removed at the last possible stage during the installation process. It is possible to selectively move the coating to one side to avoid fastenings and joints. Then finally remove the coating from the installed product.

WARNING – Do not leave products with strippable coating exposed to direct sunlight for more than about a week or it can become difficult to remove.

Installation Steps

Stramit Strongline® Fascia

1. Cut **Stramit Strongline®** Fascia to suit a straight run.
2. Position and level rafter brackets at each end of the run and fix to the rafters.
3. Slide **Stramit Strongline®** Fascia over one end and slide along to the other end (or lift over brackets) if End Fixed Brackets are used.
4. Insert remaining rafter brackets at required spacings and fix to rafters (if not End Fixed Brackets).
5. Repeat for each straight run, and then attach accessories.

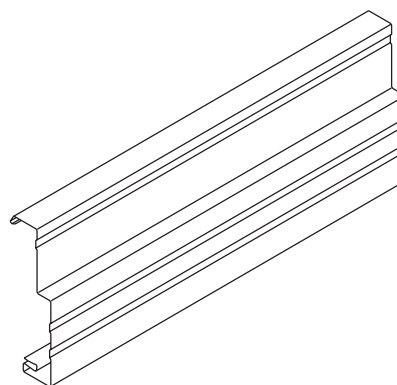

Stramit® Gutters

For fixing to Stramit Strongline® Fascia:

1. Cut **Stramit®** Gutter to suit a straight run, including downpipe outlet holes and end mitres.
2. Place gutter onto **Stramit Strongline®** Fascia step and push clip brackets over fascia at no greater than maximum support spacing for the particular product.
3. Attach brackets to fascia using No. 10 x 16mm self-drilling screws.
4. Repeat for each straight run, and then attach accessories.

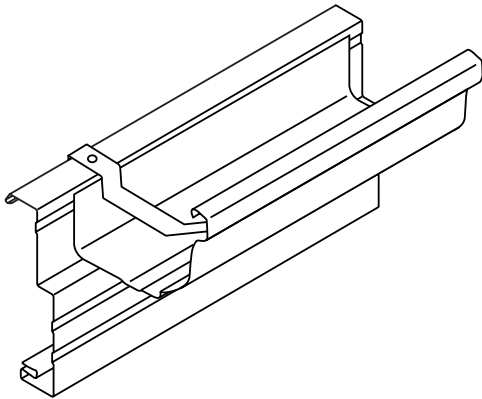

For fixing to timber fascia using concealed brackets:

1. Cut **Stramit®** Gutter to suit a straight run, including downpipe outlet holes and end mitres.
2. Position a bracket at the high end of the run and fix to the fascia.
3. Position and fix bracket at the other end of the run using a string line to set the required fall (recommended minimum 1 in 500).
4. Position and fix intermediate brackets at no greater than maximum support spacing for the particular product.
5. Hook gutter to front of brackets, swing into position and fold down bracket tabs to secure, then for each fascia type.
6. Repeat for each straight run, and then attach accessories.

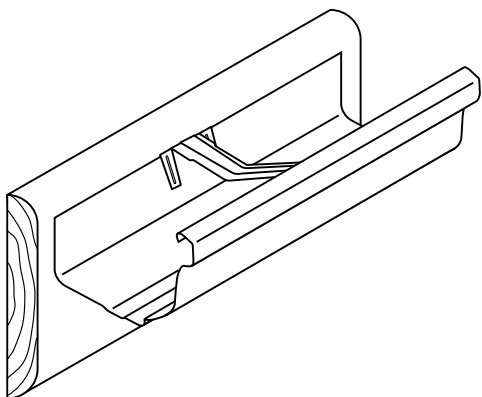

For fixing to timber fascia using external brackets:

1. Cut **Stramit®** Gutter to suit a straight run, including downpipe outlet holes and end mitres.
2. Position external bracket at the high end of the run and fix to the fascia.
3. Position and fix bracket at the low end of the run using a string line to set the required fall (recommended minimum 1 in 500).
4. Using the string line as a guide position and fix intermediate brackets at no greater than maximum support spacing for the particular gutter.
5. Place the gutter onto the brackets and secure in position by folding down the front (and back for some products) tabs.
6. Repeat for each straight run, and then attach accessories.

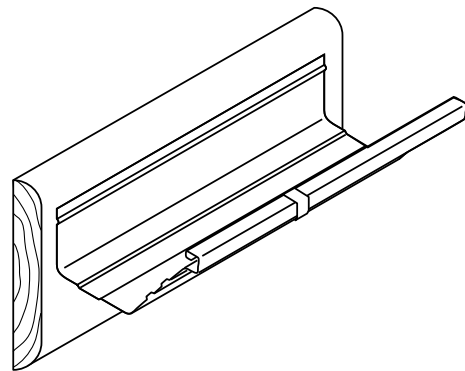

Stramit® Downpipes

Installation – from the bottom of the gutter.

1. Attach pop to gutter.
2. Fit or construct the offset, preferably at an angle of at least 15° to ensure good drainage.
3. Adjust downpipe height to suit.
4. Secure downpipes to the wall using at least one downpipe strap per downpipe (minimum two).

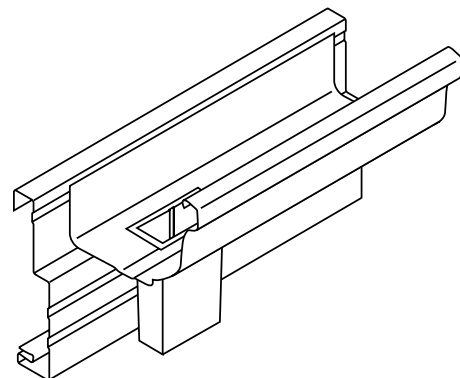

Installation – from the back of the gutter.

[Not recommended by AS3500.3]

1. Cut through back of fascia down to step and install Fascia Bridging Plate.
2. Cut through back of gutter and cut, splay and insert downpipe, sealing before attaching using rivets.
3. Fit downpipe/offset to nozzle with fall to ensure drainage.
4. Adjust downpipe height to suit.
5. Secure downpipe to the wall using at least one-downpipe strap per downpipe (minimum of two).

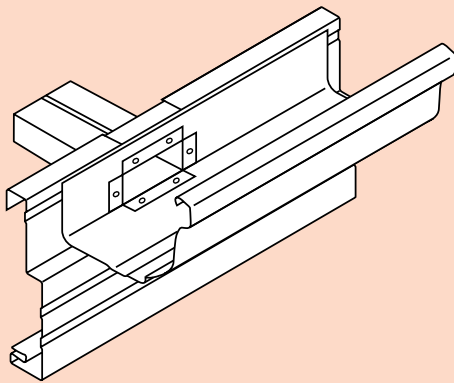

Additional Information

Maintenance

Exterior surfaces of metal products unwashed by rain can benefit from occasional washing. These areas include portions of fascia and the underside of accompanying gutters.

Further Information

As well as the standard range of Technical Manuals, Installation Leaflets, Case Studies and other promotional literature, Stramit has a series of Guides to aid design.

These include:

- Roof Slope Guide
- Concealed Fixed Decking
- Foot Traffic Guide
- Roof and Wall Sheeting
- Lightweight Structural Sections
- Truss Components
- Gutters and Downpipes
- Custom Flashings
- Insulation Products

Other Products

Stramit offers a wide range of building products including:

- Purlins and Girts
- Formwork Decking
- Roof and Wall Sheeting
- Lightweight Structural Sections
- Truss Components
- Gutters and Downpipes
- Custom Flashings
- Insulating Products

Registered Designs

Stramit Strongline[®] Fascia, fascia bracket, all gutter stiffener brackets and **Stramit**[®] Barge Gutter are protected in Australia by registered designs and/or patent.

References

In preparing this document reference has been made to:

- Standards Australia Handbook – HB39
(Installation code for metal roof and wall cladding)

		prices	availability	general	technical
contact numbers for information			products coating colours	other	advice product data
SYDNEY 33-83 Quarry Rd, Erskine Park NSW 2759	phone fax	(02) 9834 0909 (02) 9834 0988		(02) 9834 0900 (02) 9834 0988	
CANBERRA 4 Bass Street, Queanbeyan NSW 2620	phone fax	(02) 6132 8300 (02) 6132 8333			
COFFS HARBOUR 6 Mansbridge Drive, Coffs Harbour NSW 2450	phone fax	(02) 6656 3800 (02) 6656 3808			
NEWCASTLE 17 Nelson Road, Cardiff NSW 2285	phone fax	(02) 4041 3400 (02) 4041 3423			
ORANGE 51 Leewood Drive, Orange NSW 2800	phone fax	(02) 6363 3900 (02) 6363 3911			
MELBOURNE 2/1464 Ferntree Gully Road, Knoxfield VIC 3180	phone fax	(03) 9237 6300 (03) 9237 6399		(03) 9237 6200 (03) 9237 6299	
ALBURY 18 Ariel Drive, Albury NSW 2640	phone fax	(02) 6041 7600 (02) 6041 7666			
BENDIGO Ramsay Court, Kangaroo Flat VIC 3555	phone fax	(03) 5448 6400 (03) 5447 9677			
HOBART 57 Crooked Billett Drive, Brighton TAS 7030	phone fax	(03) 6262 8888 (03) 6262 8812			(03) 6262 8888 (03) 6262 8812
ADELAIDE 11 Stock Road, Cavan SA 5094	phone fax	(08) 8262 4444 (08) 8262 6333			(08) 8262 4444 (08) 8262 6333
BRISBANE 57-71 Platinum Street, Crestmead QLD 4132	phone fax	(07) 3803 9999 (07) 3803 1499			
TOWNSVILLE 402-408 Bayswater Road, Garbutt QLD 4814	phone fax	(07) 4412 3900 (07) 4412 3909			
CAIRNS Vickers Street, Edmonton QLD 4869	phone fax	(07) 4034 6555 (07) 4034 6511			
MACKAY Brickworks Court, Glenella QLD 4740	phone fax	(07) 4965 4000 (07) 4965 4012			(07) 3803 9999 (07) 3803 1499
MARYBOROUGH 10 Activity St, Maryborough QLD 4650	phone fax	(07) 4123 9500 (07) 4123 9508			
ROCKHAMPTON 41 Johnson St, Parkhurst QLD 4702	phone fax	(07) 4921 5600 (07) 4921 5608			
DARWIN 55 Albatross Street, Winnellie NT 0820	phone fax	(08) 8930 6333 (08) 8930 6308			
PERTH 605-615 Bickley Road, Maddington WA 6109	phone fax	(08) 9493 8800 (08) 9493 8899			